

Guarde esse manual ele pode servir para futuras consultas em caso de avarias, lembrando que nossos móveis tem garantia de 2 anos.

Para a segurança do seu bebê, leia com muita atenção todas as instruções antes de iniciar a montagem.



## CÔMODA 4 GAVETAS Luis XVII

L. 103,5 / A. 106 / P. 50,5 cm

28/02/18 - REV. 02

Válido a partir do lote: 18/0028



montagem  
2 pessoas



tempo  
2 horas aproximadamente



ferramentas  
Martelo de borracha



quantidade de volumes  
3 caixas

MANUAL DE MONTAGEM



[www.tulipababy.com.br](http://www.tulipababy.com.br)

Fabricante Móveis Caftor Ltda. Rua Dona Francisca, 4363 - Rio Negrinho/SC - 89295-000 - CNPJ 95.850.806/0001-85

Revendedor Exclusivo: Móveis Get Ltda. - Rodovia BR 280, 2015 - Rio Negrinho/SC - 89295-000 - CNPJ : 14.013.165/0001-02

# Importante ler com atenção e guardar para eventuais consultas

Antes de iniciar a montagem deste produto, confira todo o conteúdo das peças e componentes conforme indicado na página 3. Em caso de alguma divergência, entre em contato imediatamente com a loja onde o mesmo foi comprado para solução do problema.

A não observância desta instrução exime o fabricante de quaisquer responsabilidades futuras.



A montagem do produto deverá ser feita em uma superfície limpa e plana, aconselhamos utilizar a embalagem para forrar o chão a fim de não danificar o produto;



Para evitar acidentes domésticos no momento da montagem e manuseio das peças do móvel é aconselhável evitar a presença de crianças;



O ambiente onde estará o móvel deve ser arejado e sem bolor, pois esse pode transferir-se ao móvel novo. Importante: a garantia não cobre peças emboloradas e ataques de pragas.

## Após a montagem



Não arrastar o móvel, pois pode ocasionar comprometimento da parte estrutural;



Esteja ciente do risco de chama aberta e outras fontes de calor, tais como aquecedores elétricos, aquecedores a gás etc. nas proximidades do berço;



Verificar se todos os acessórios utilizados na montagem estão bem apertados e que não exista nenhum parafuso ou acessório solto, evitando assim o perigo da criança se ferir ou enroscar na roupa (como por exemplo: cordões, colares, fitas para bonecas, etc.); Verificar periodicamente se os parafusos estão bem apertados;



Para evitar perigo de sufocamento, remover plásticos que acompanham a embalagem e destruí-los ou mantê-los longe do alcance de bebês e crianças.

# CÔMODA MENOR 4 GAVETAS Luis XVII

É importante guardar o manual de montagem, lembrando que nossos móveis tem garantia de 2 anos.



## Partes do produto

### Caixa 1/3

Partes: 1 (tampo),  
2 (travessa frontal),  
3 (travessa traseira),  
4 (quadro lateral esquerdo),  
5 (travessa lateral inferior),  
8 (quadro lateral direito),  
11 (encosto traseiro),  
12 (travessa esquerda superior),  
13 (travessa direita superior),  
14 (travessa traseira superior),  
16 (lateral gaveta),  
17 (fundo de gaveta),  
18 (traseiro gaveta),  
Perfil «H», manual de montagem.

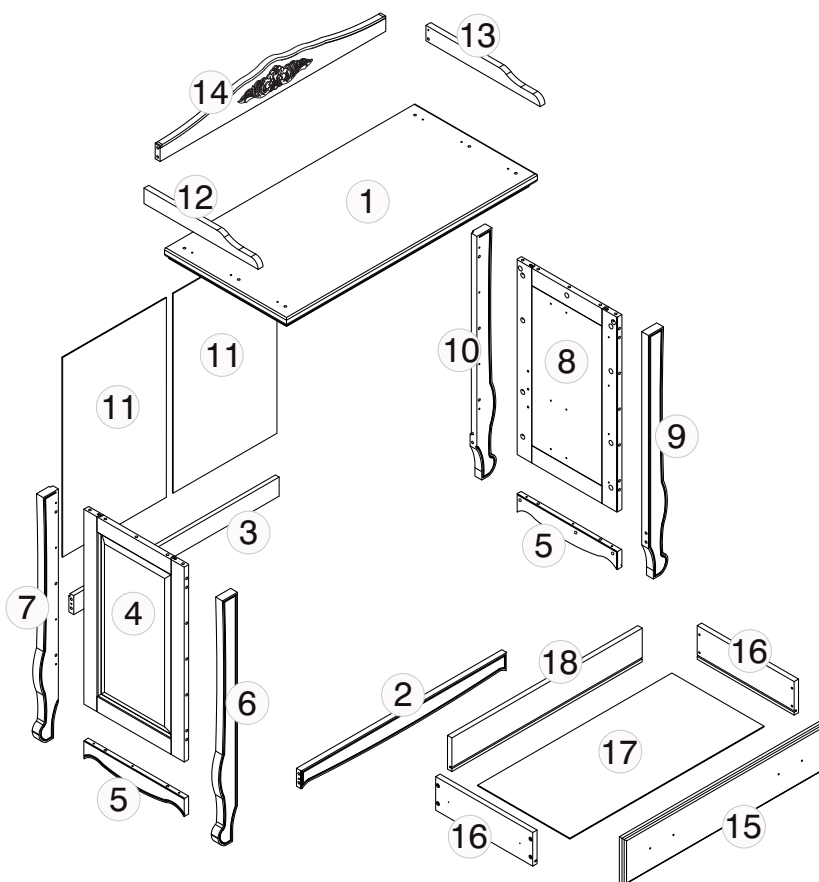

### Caixa 2/3

Partes: 6 (pé esquerdo frontal),  
7 (pé esquerdo traseiro),  
9 (pé direito frontal),  
10 (pé direito traseiro)  
e 15 (frente gaveta).

### Caixa 3/3

Partes: ferragens.

## Acabamento MEL

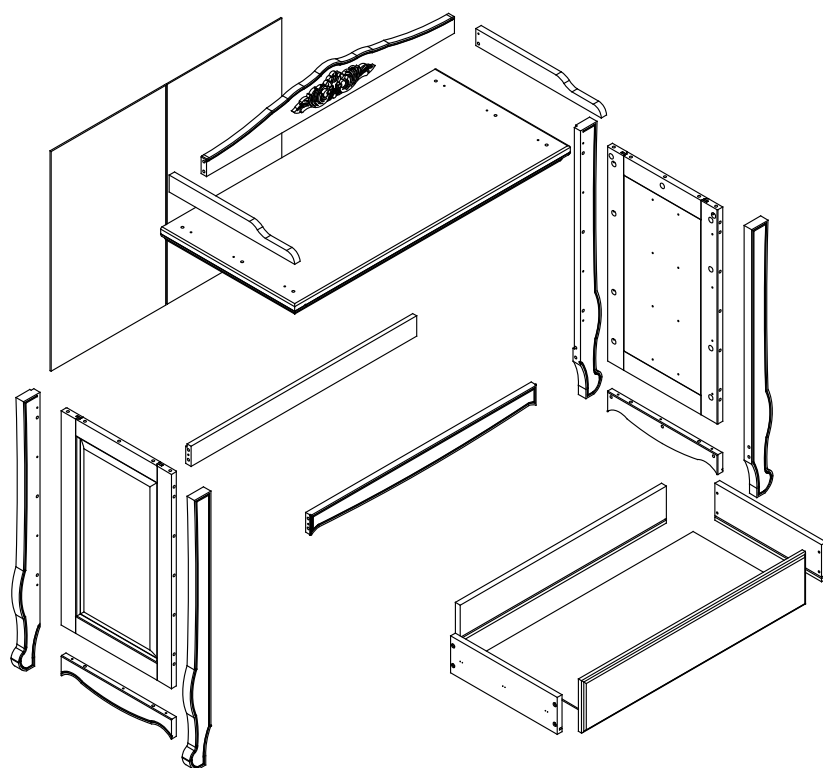

○ Peças de madeira

## Acabamento BRANCO c/ DESGASTE

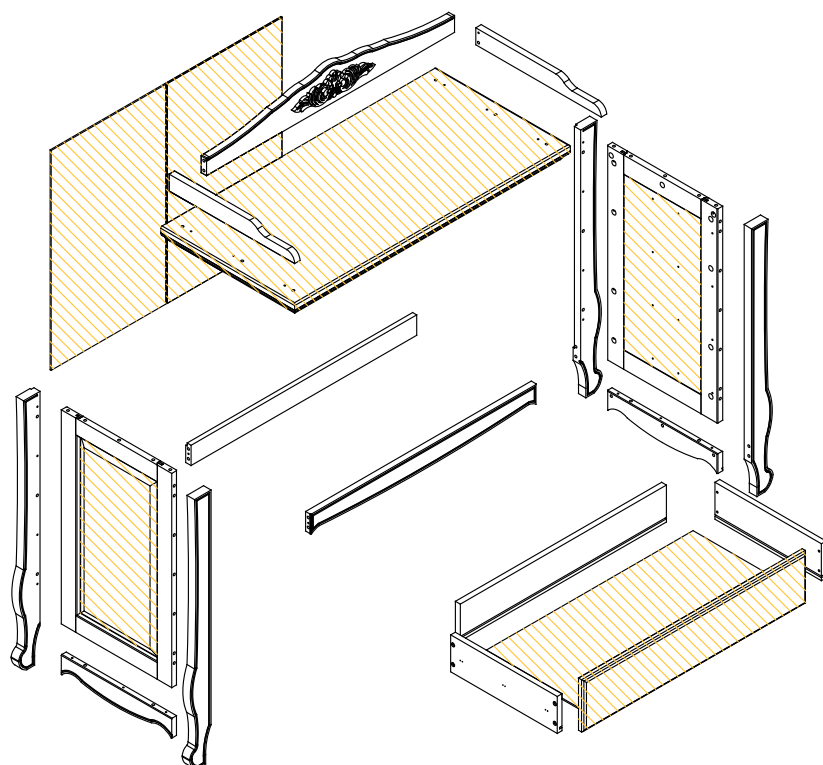







▨ Peças de MDF

○ Peças de madeira

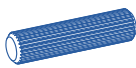
# Ferramentas/ferragens

As ferramentas e ferragens de montagem se encontram na terceira caixa.

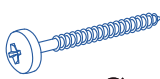
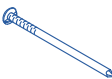
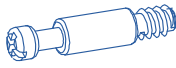
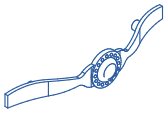
## Caixa 3/3

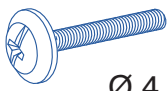
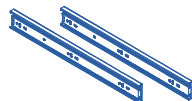
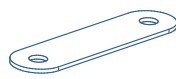
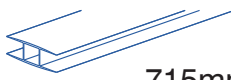
a	 Ø 8 x 30	36 pçs	h	 Ø 6 x 10	24 pçs
b	 Ø 3,5 x 16	30 pçs	i	 Ø 4 x 35	32 pçs
c	 Ø 4 x 35	16 pçs	j		26 pçs
d		24 pçs	k		8 pçs
e		24 pçs	l	 Ø 4 x 30	16 pçs
f		4 pçs	m		3 pçs
g	 715mm	1 pçs			

ferragens

# Corrediça telescópica: detalhes

Dividir a ferragem **f** em duas partes: **f1** e **f2**

**f1** - Serão fixada nas laterais do móvel.

**f2** - Serão fixadas nas laterais da gaveta.

Abra a corrediça conforme desenho, incline levemente a trava para cima

(conforme detalhe) e libere a peça **f2**.

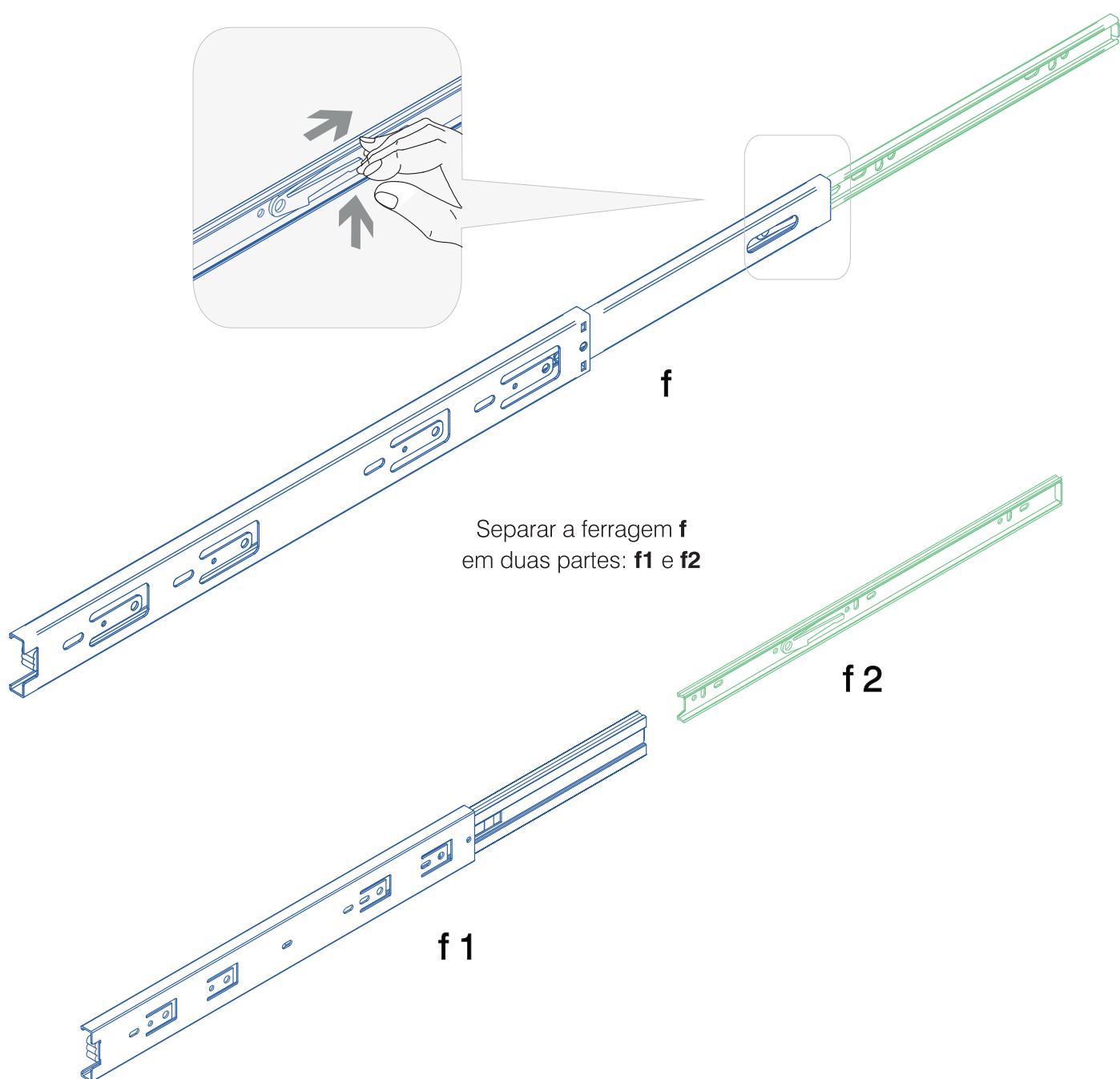

<b>1</b>	<b>2</b>	<b>3</b>	<b>4</b>	<b>5</b>	<b>6</b>	<b>7</b>
<b>8</b>	<b>9</b>	<b>10</b>	<b>11</b>	<b>12</b>	<b>13</b>	<b>14</b>

**Cômoda**

4 gavetas

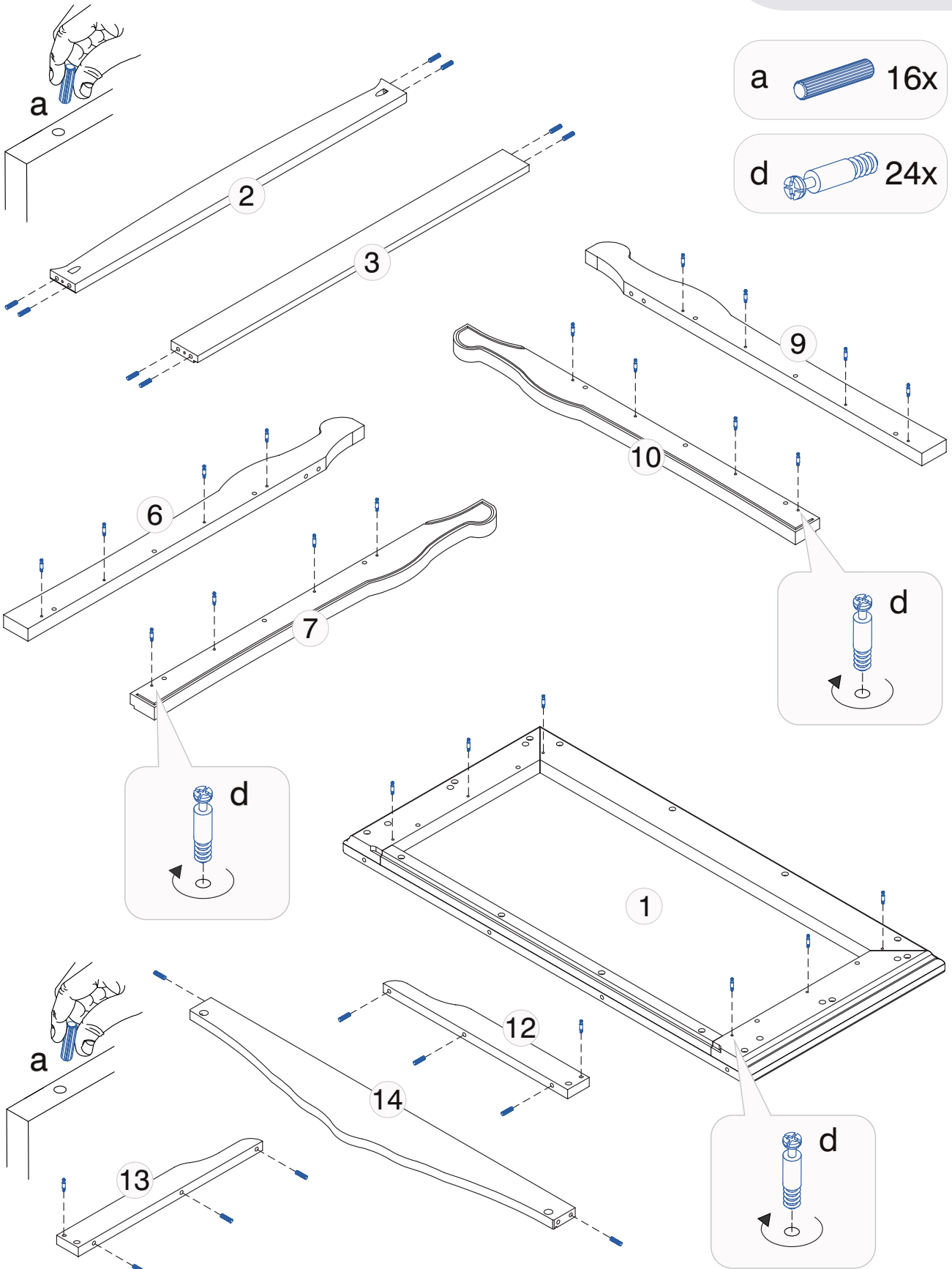

1	2	3	4	5	6	7
8	9	10	11	12	13	14

Cômoda

4 gavetas

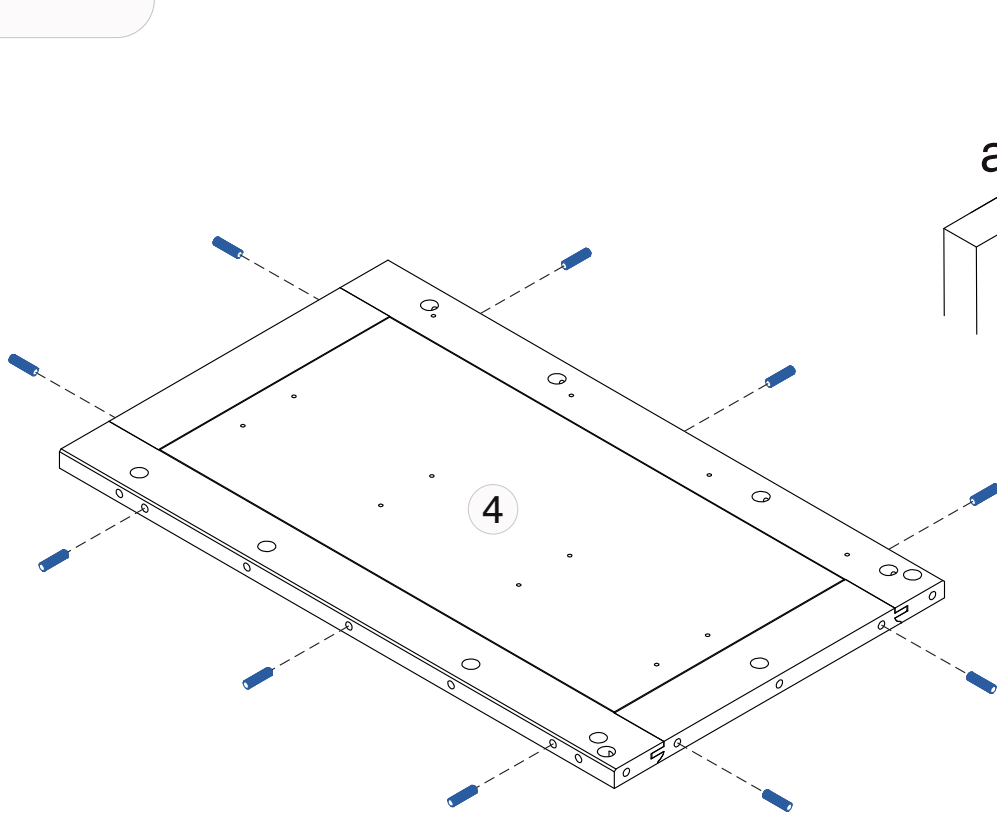
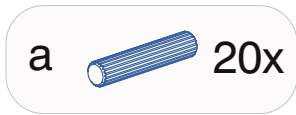
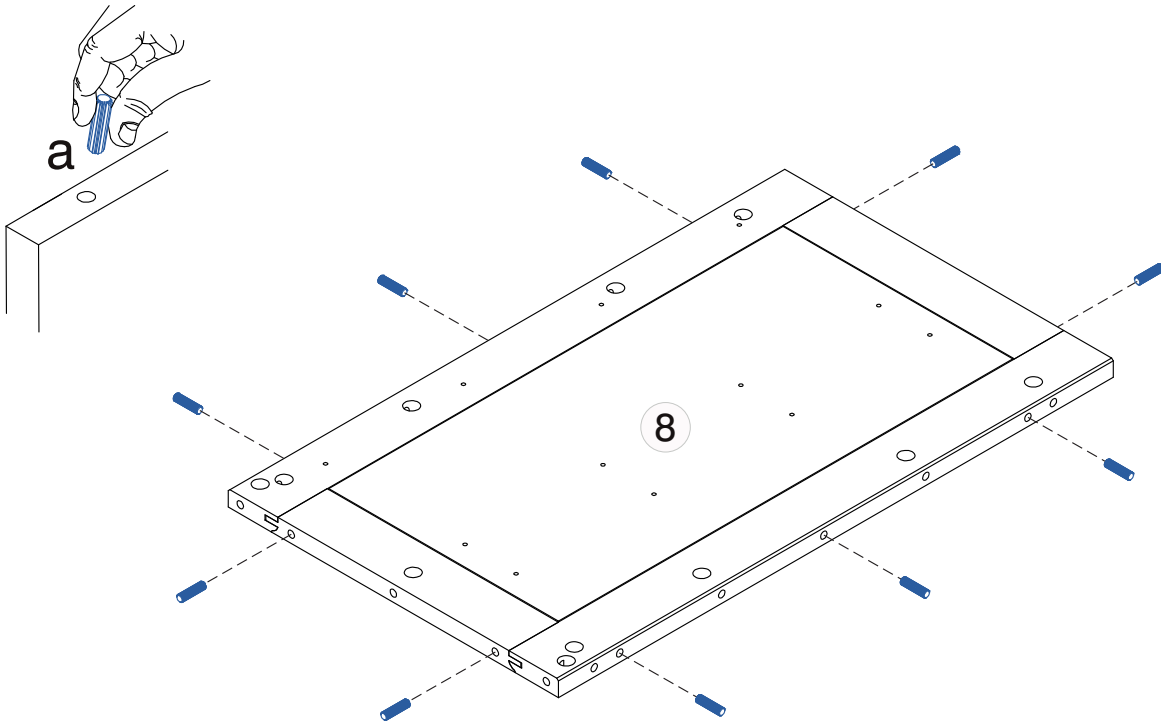



1	2	3	4	5	6	7
8	9	10	11	12	13	14

Cômoda

4 gavetas

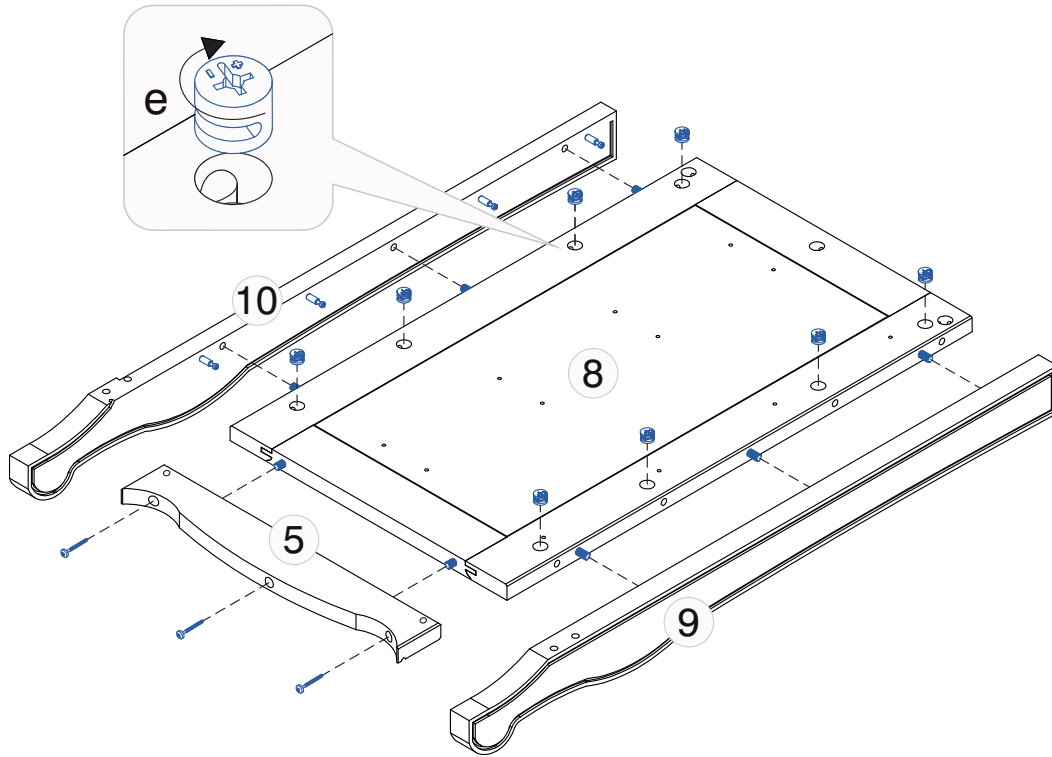

e  16x

c  6x

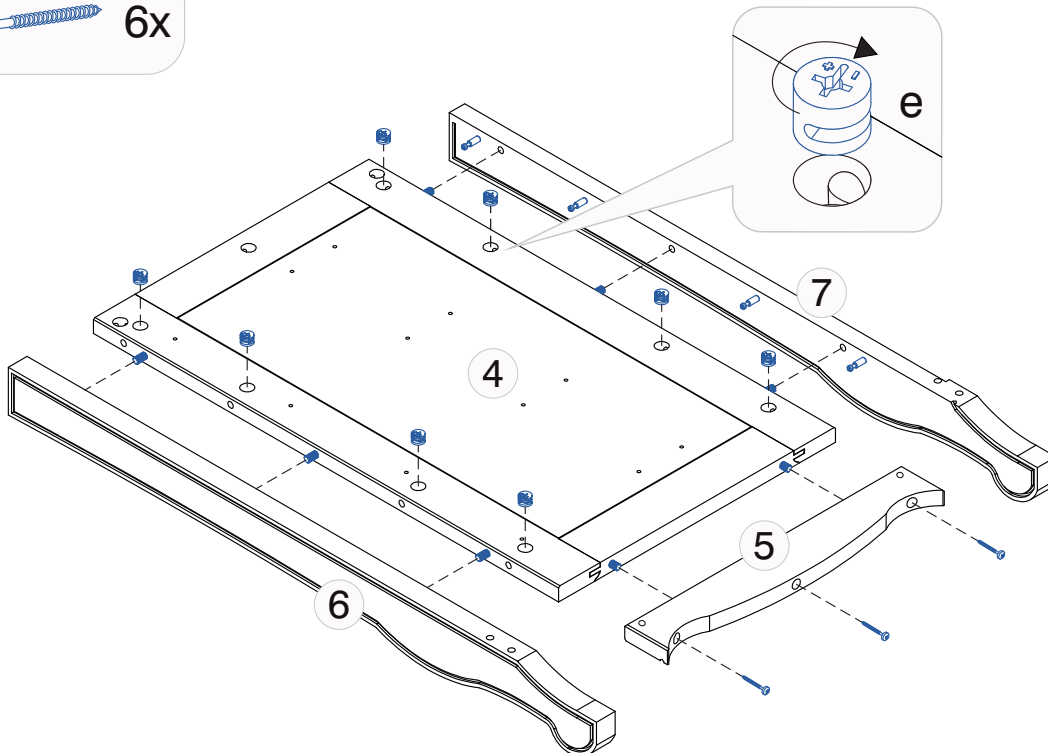

1	2	3	4	5	6	7
8	9	10	11	12	13	14

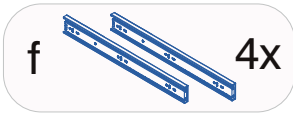
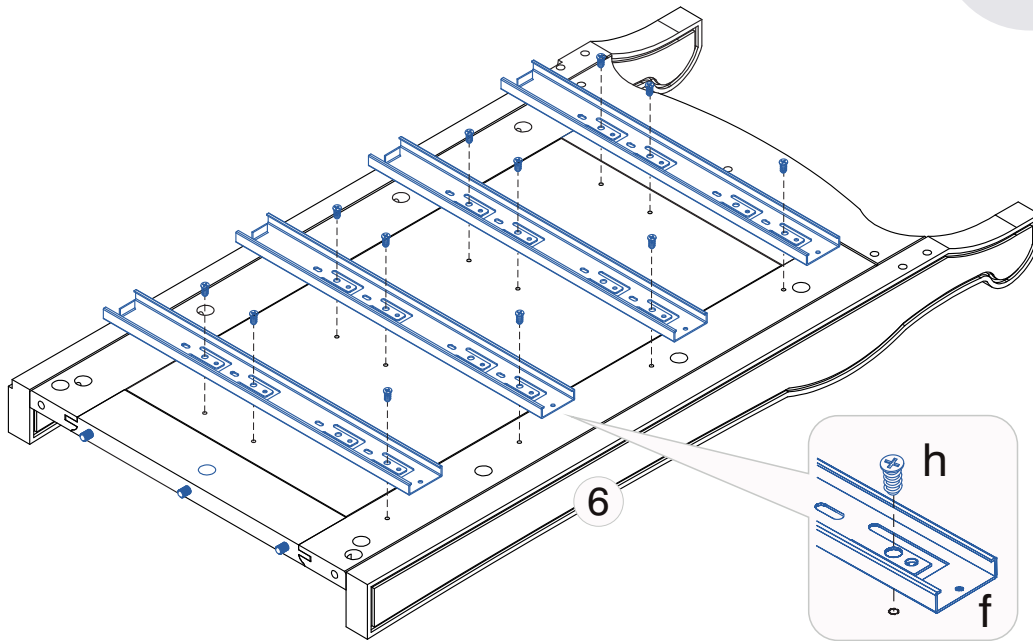

Aplicar o parafuso h conforme detalhe abaixo.

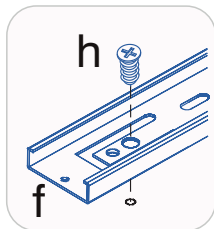
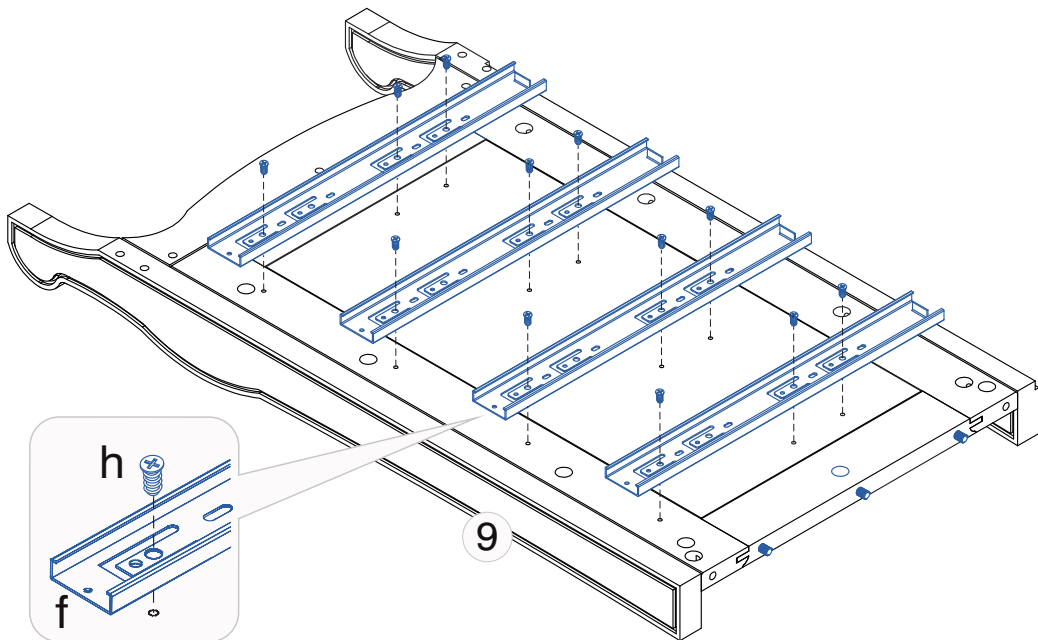
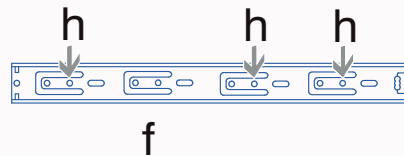

Aplicar o parafuso h conforme detalhe abaixo.

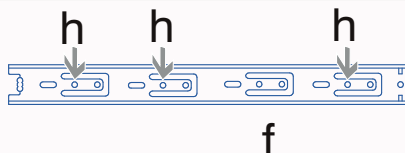

1	2	3	4	5	6	7
8	9	10	11	12	13	14

Cômoda

4 gavetas

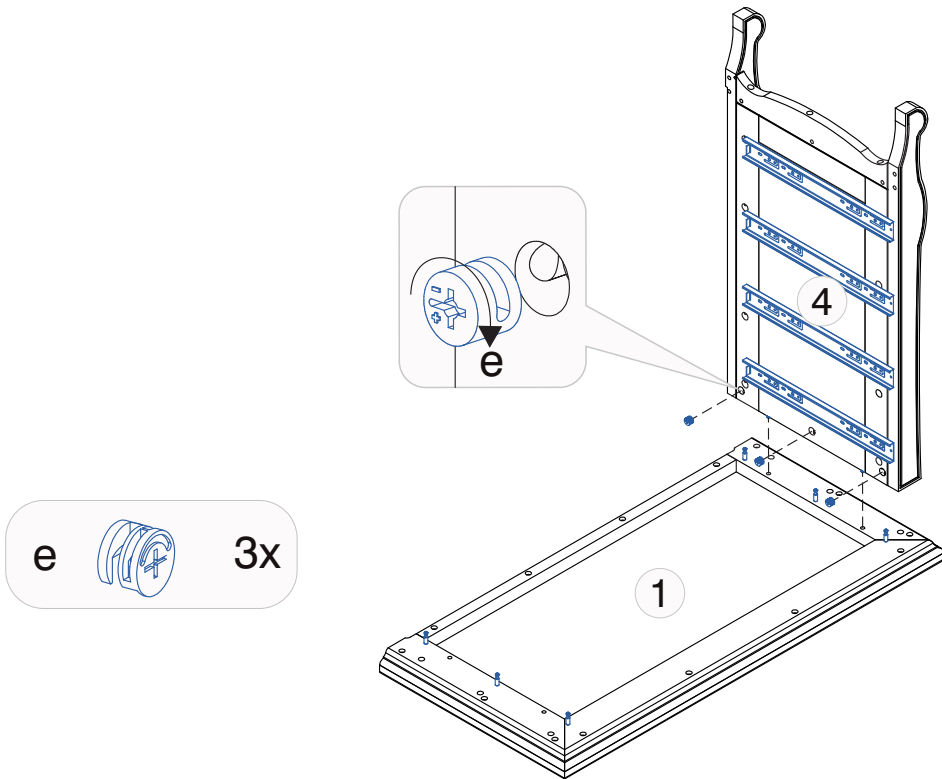

1	2	3	4	5	6	7
8	9	10	11	12	13	14

Cômoda

4 gavetas

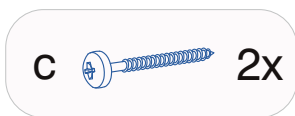
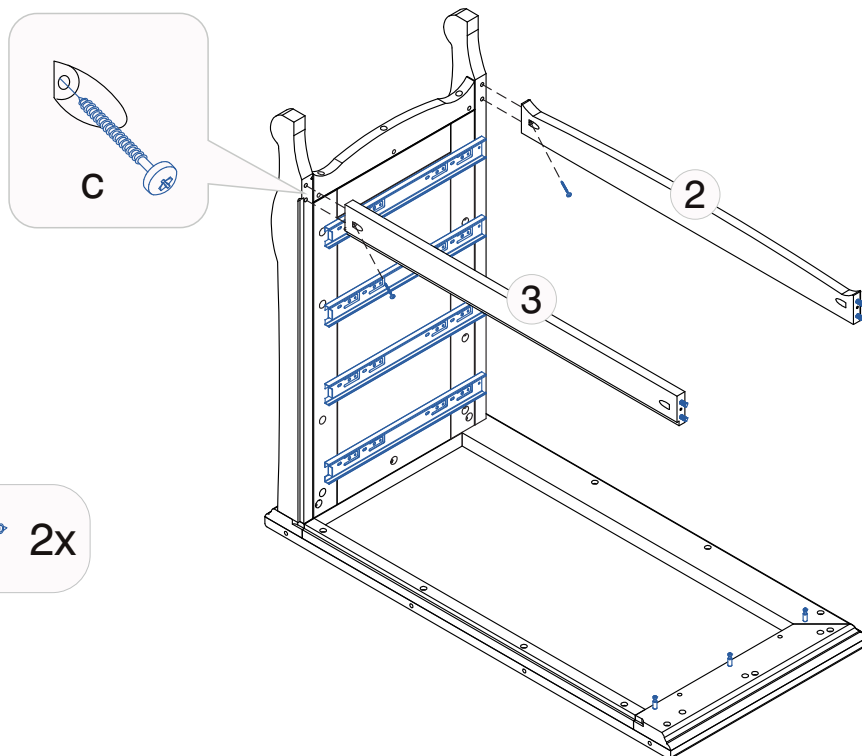

1	2	3	4	5	6	<b>7</b>
8	9	10	11	12	13	14

Cômoda

4 gavetas

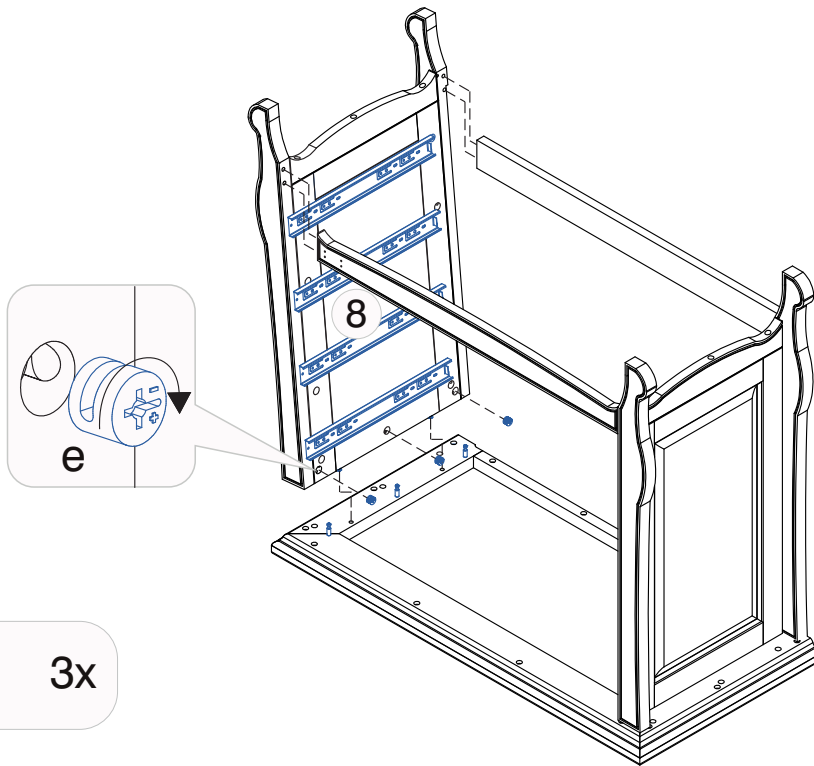

1	2	3	4	5	6	7
<b>8</b>	9	10	11	12	13	14

Cômoda

4 gavetas

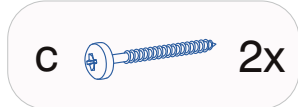
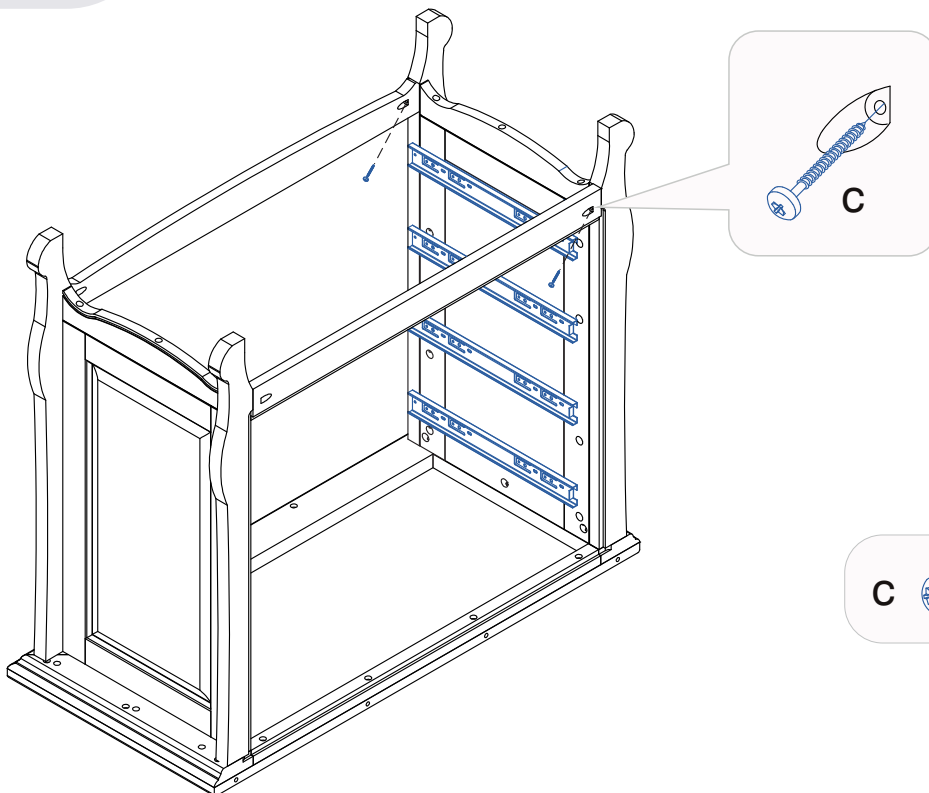

1	2	3	4	5	6	7
8	9	10	11	12	13	14

Cômoda

4 gavetas

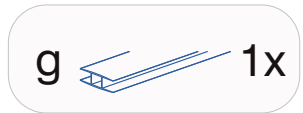
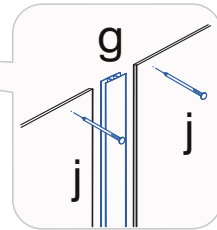
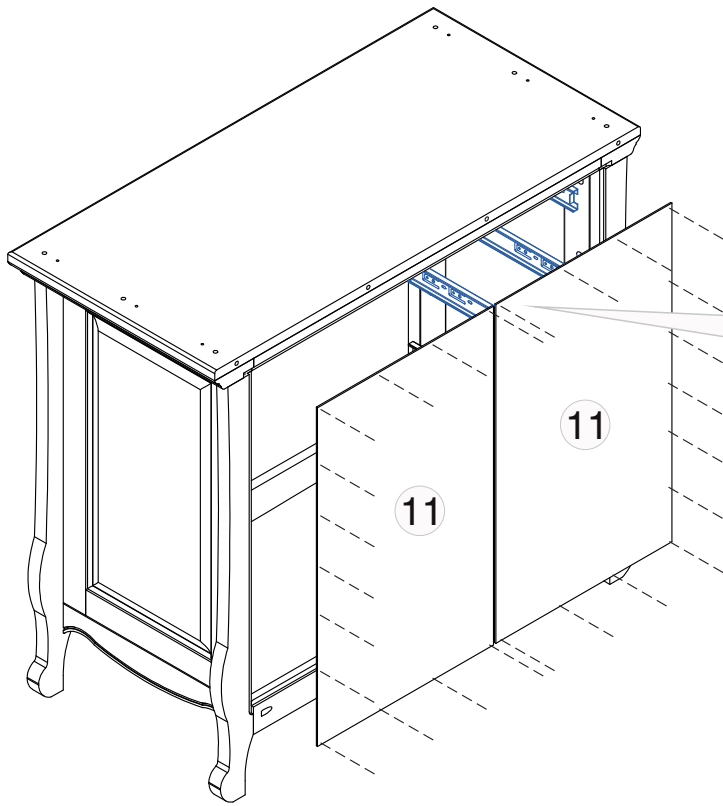

Cômoda

4 gavetas

1	2	3	4	5	6	7
8	9	10	11	12	13	14

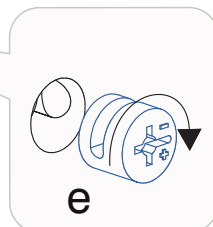
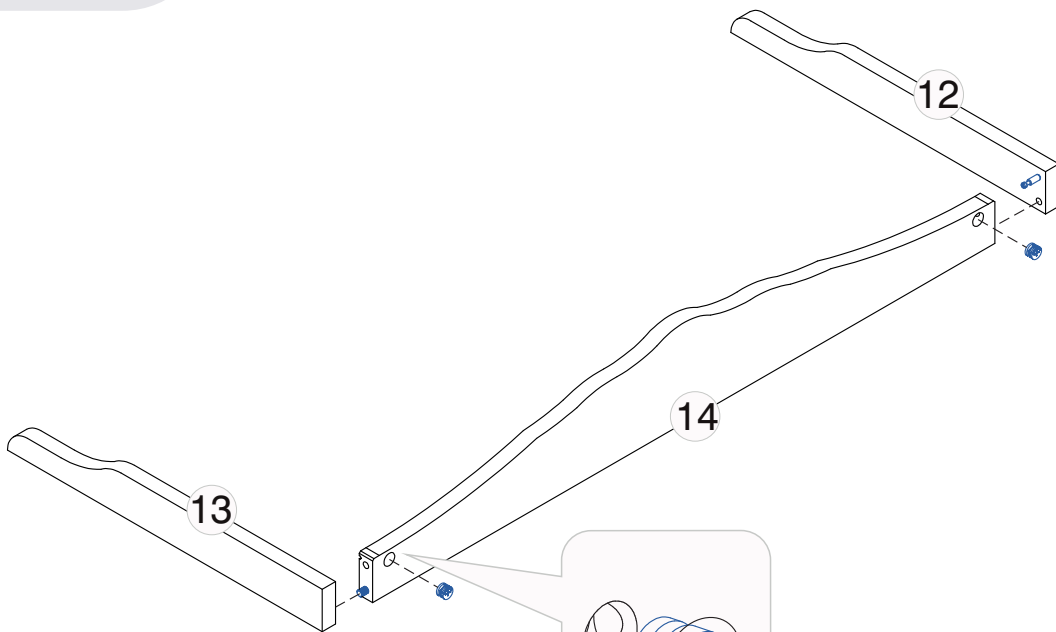

1	2	3	4	5	6	7
8	9	10	11	12	13	14

Cômoda

4 gavetas

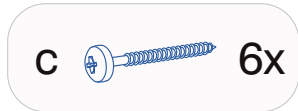
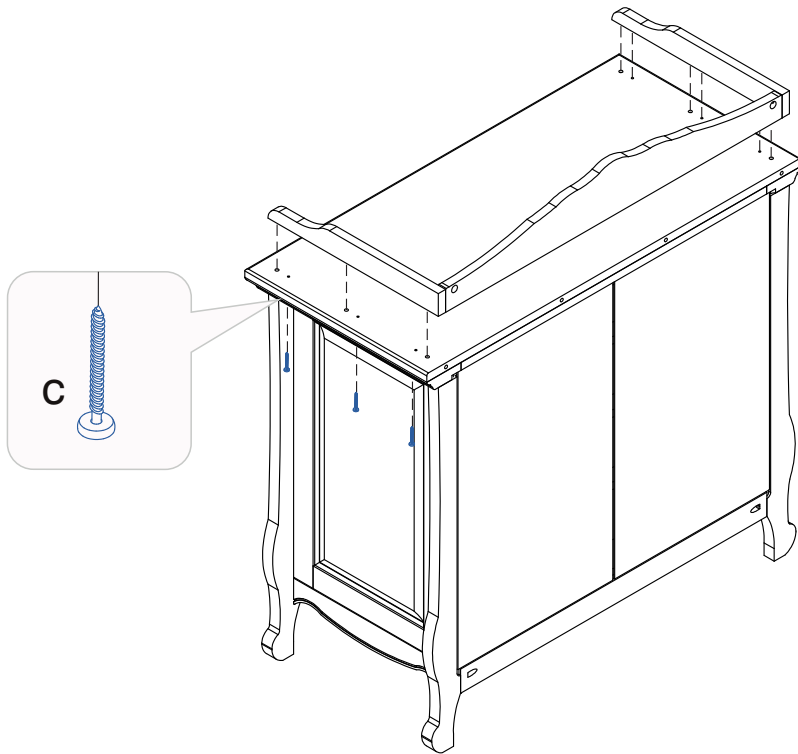

Cômoda

4 gavetas

1	2	3	4	5	6	7
8	9	10	11	12	13	14

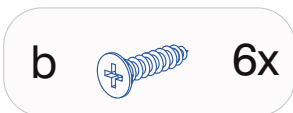
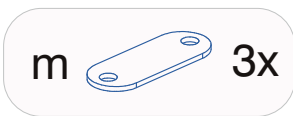
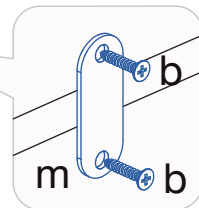
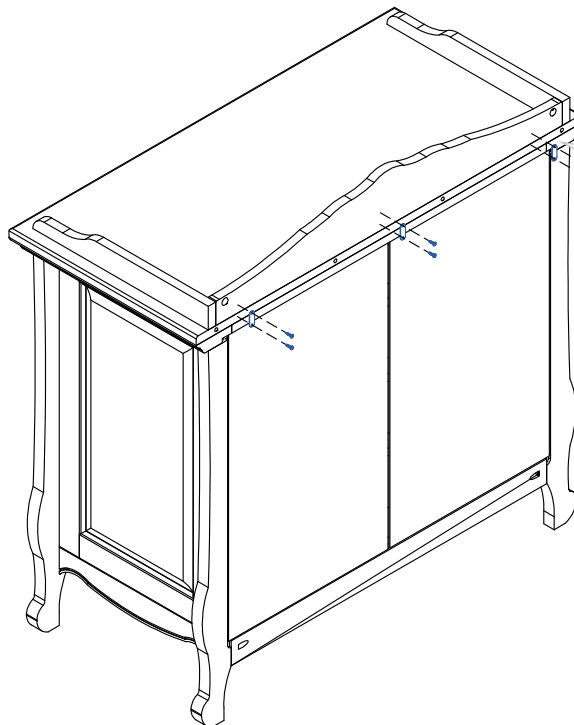

1	2	3	4	5	6	7
8	9	10	11	12	13	14

Cômoda

4 gavetas

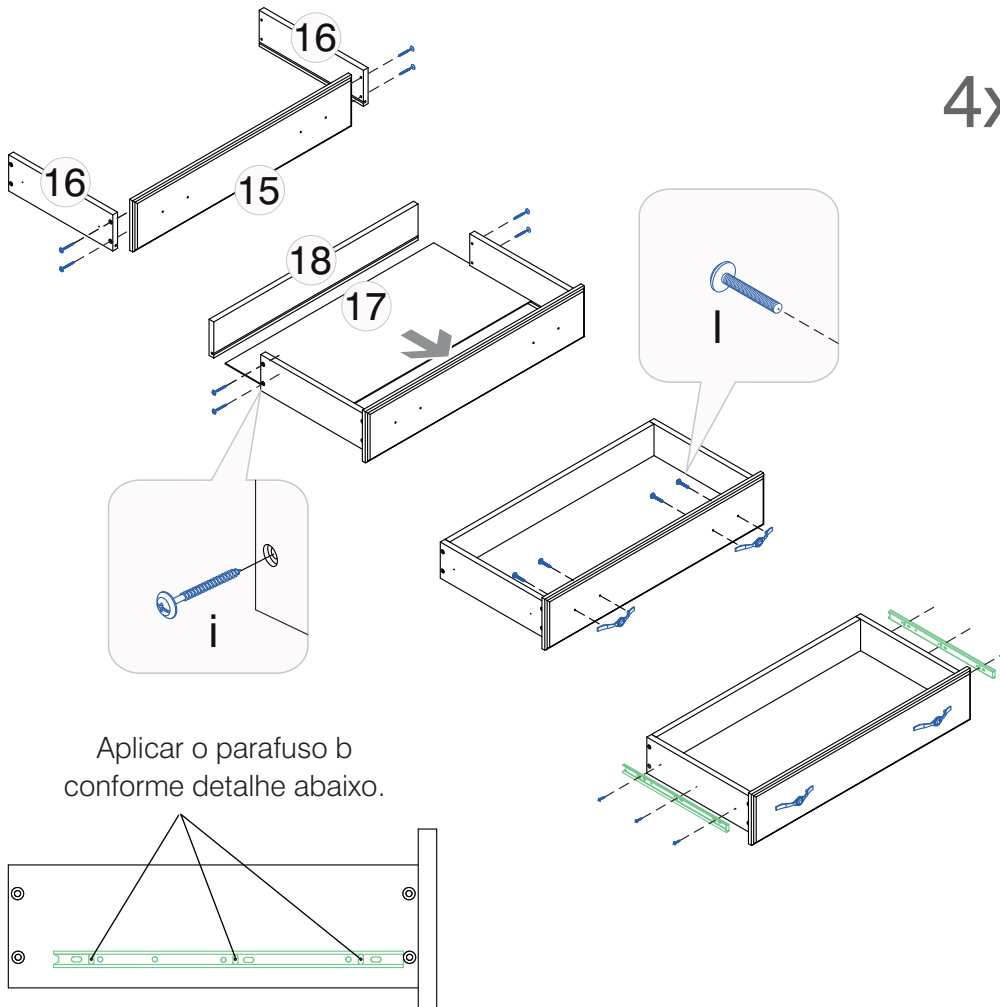

4x Aplicar esses 4 passos nas 4 gavetas.

b 24x

l 16x

k 8x

f 4x

i 32x

Cômoda	1	2	3	4	5	6	7
4 gavetas	8	9	10	11	12	13	14

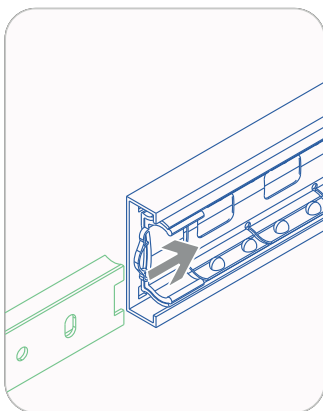

1º Certifique-se que a haste com rolamentos esteja na parte frontal do trilho.

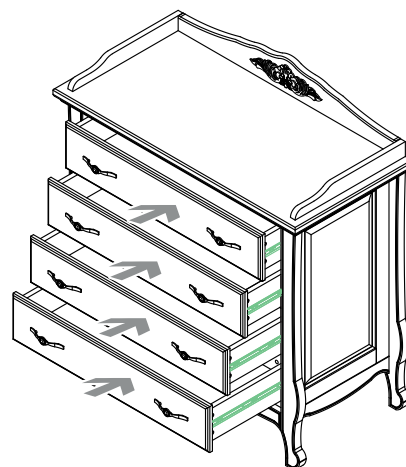

2º Após encaixar a haste no trilho, empurre a gaveta até o fechamento por completo, forçando para passar da trava.

# Instalação do kit anti-tombamento

Acidentes graves ou fatais podem ocorrer no caso de tombamento da cômoda.

Para prevenir acidentes siga as instruções deste manual.

A etiqueta conforme imagem abaixo está fixada na parte interna da 1ª gaveta. Não removê-la.



## ATENÇÃO





**Risco de acidente fatal ou sequelas permanentes se a cômoda tombar. Para evitar ou eliminar o risco, seguir as seguintes instruções:**

- Coloque objetos mais pesados na parte mais interna da gaveta;
- Não colocar televisões ou objetos pesados em cima deste produto;
- Nunca permita que crianças escalem ou se pendurem nas gavetas, portas ou prateleiras deste produto;
- Nunca abra mais de uma gaveta ao mesmo tempo;
- Nunca remova as travas ou sistema de bloqueio das gavetas.

**Utilize a ferragem anti-tombamento para reduzir ou eliminar o risco de tombamento deste produto.**

Esta é uma marcação permanente. Não remova!

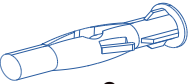
### Peças

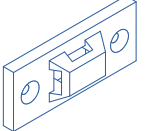
a	 3,5 x 16	4 pçs
b	 4,5 x 45	4 pçs
c	 6mm	4 pçs
d	 2	2 pçs
e		4 pçs

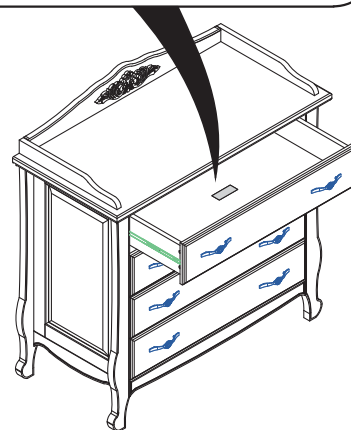

Utilize a ferragem anti-tombamento para reduzir ou eliminar o risco de tombamento deste produto conforme orientações a seguir.



Ferramentas necessária para a montagem



Martelo de borracha



Chave phillips



Furadeira com broca de 6mm



Trena



# Instalação do kit anti-tombamento

1° Fixar na parede na altura conforme a imagem ao lado

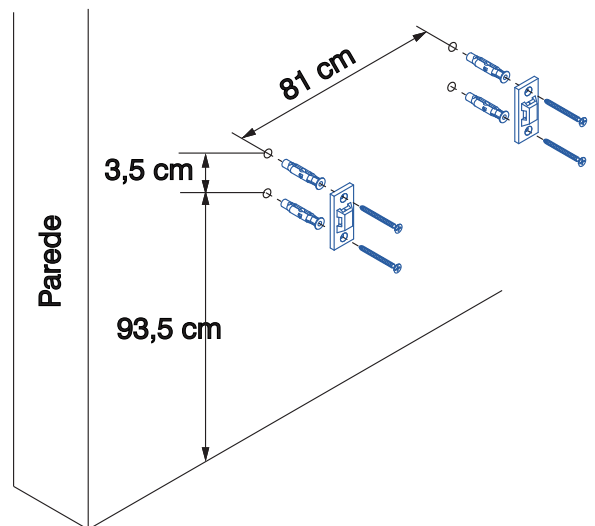
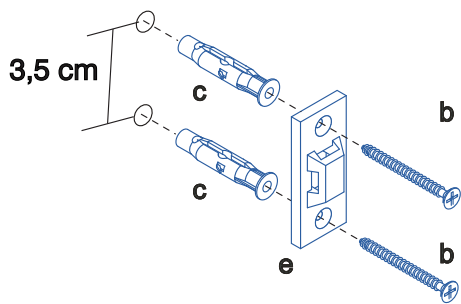

2° Fixar na face traseira da travessa

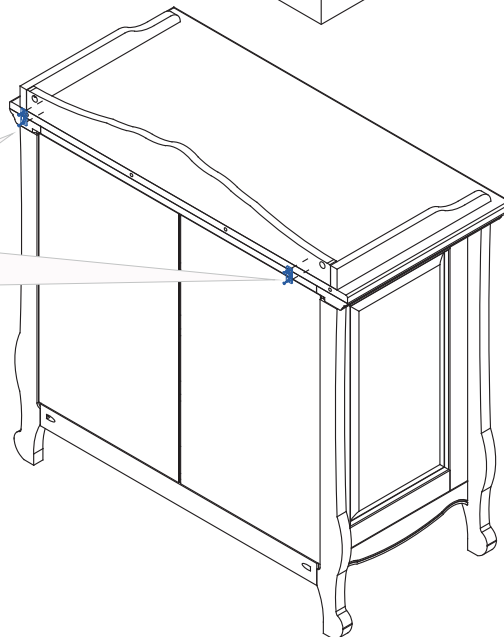
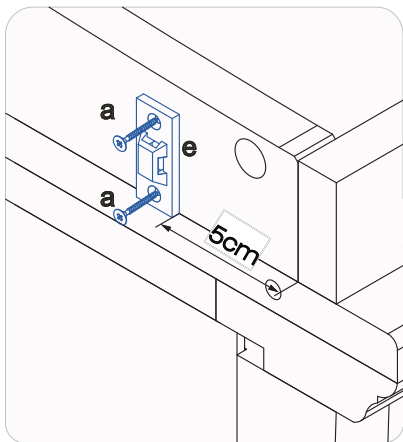

3° Unir as peças e utilizando ferragem d

